

12 VOLT SINGLE-PHASE ALTERNATOR RECTIFIER/REGULATOR CODE: RR12



APPLICATIONS:

- UNIVERSAL TYPE, SUITABLE FOR MOTORCYCLES & CARS WITH SINGLE-PHASE PERMANENT MAGNET ALTERNATORS & 12 VOLT ELECTRICS, INCLUDING TRIUMPH/BSA/NORTON SINGLES/TWINS/TRIPLES
- CAN BE USED TO CONVERT 6 VOLT, 3 WIRE ALTERNATORS TO 12 VOLT
- CAN BE WIRED FOR POSITIVE OR NEGATIVE EARTH ELECTRICS

SPECIFICATIONS:

- REGULATED OUTPUT VOLTAGE: 14.2 Volts
- CHARGING VOLTAGE: Dependent upon battery voltage and cable length to battery
- MAXIMUM POWER: 200 Watts in airflow (approx. 14 Amps @ 14.2V)
- WIRE LENGTH: 350mm from edge of casing (approx.)
- MOUNTING SLOTS: 60mm between centres,
slot sizes: 12mm long x 6.8mm wide (approx.)
- CASE SIZE: 76mm x 52mm x 30mm deep (approx.)
- TOTAL WEIGHT (INC. WIRES): 140gms. (approx.)

FITTING INSTRUCTIONS:

Locate the unit close to the battery, if possible. Do not fit into a very confined space. Allow some air space around the unit for cooling, ideally in the airflow for high load systems. Mount to the frame with two fixing bolts, nuts and washers. The case does not have to be earthed, therefore it can be rubber mounted or mounted onto a surface that is not grounded.

WIRING FUNCTIONS:

WARNING: DO NOT CONNECT THE BATTERY THE WRONG WAY AROUND

- YELLOW WIRES: ALTERNATOR INPUT
- BLACK WIRE: NEGATIVE OUTPUT
- RED WIRE: POSITIVE OUTPUT

FOR WIRING DIAGRAMS, SEE OVER THE PAGE.

Pazon : The Ultimate Spark Performance

POSITIVE EARTH WIRING

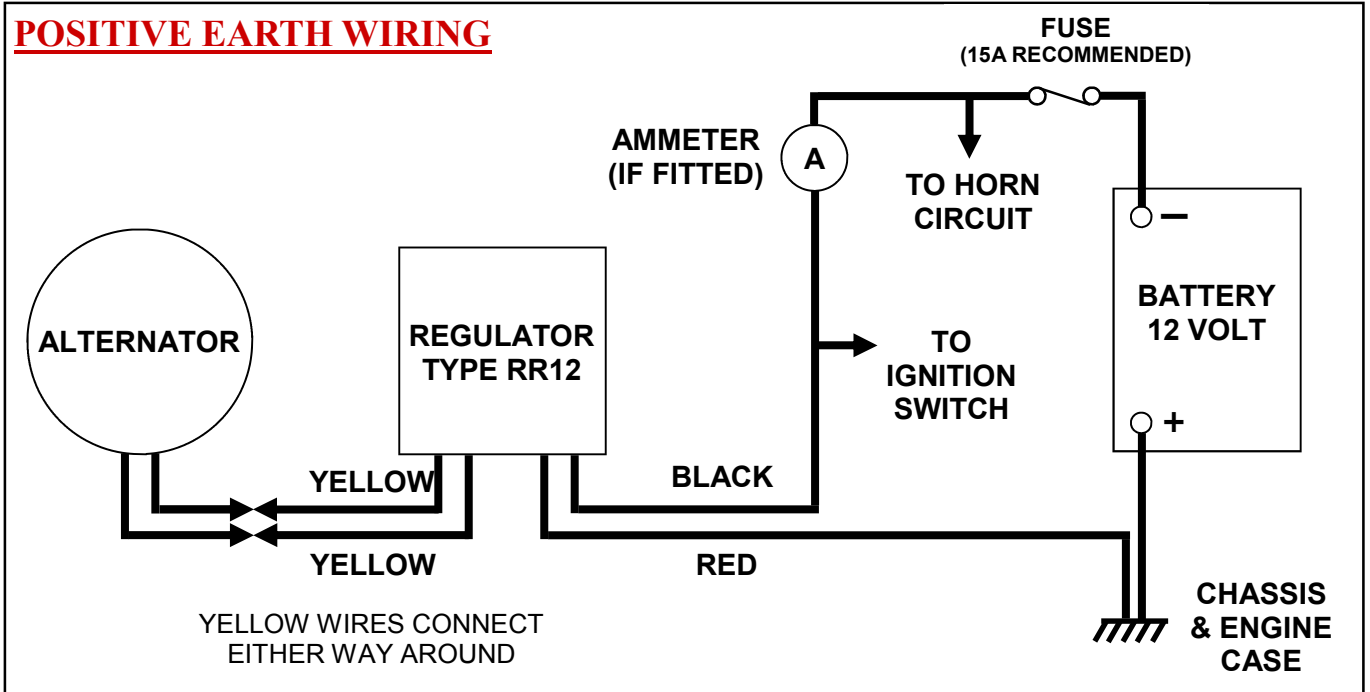

NEGATIVE EARTH WIRING

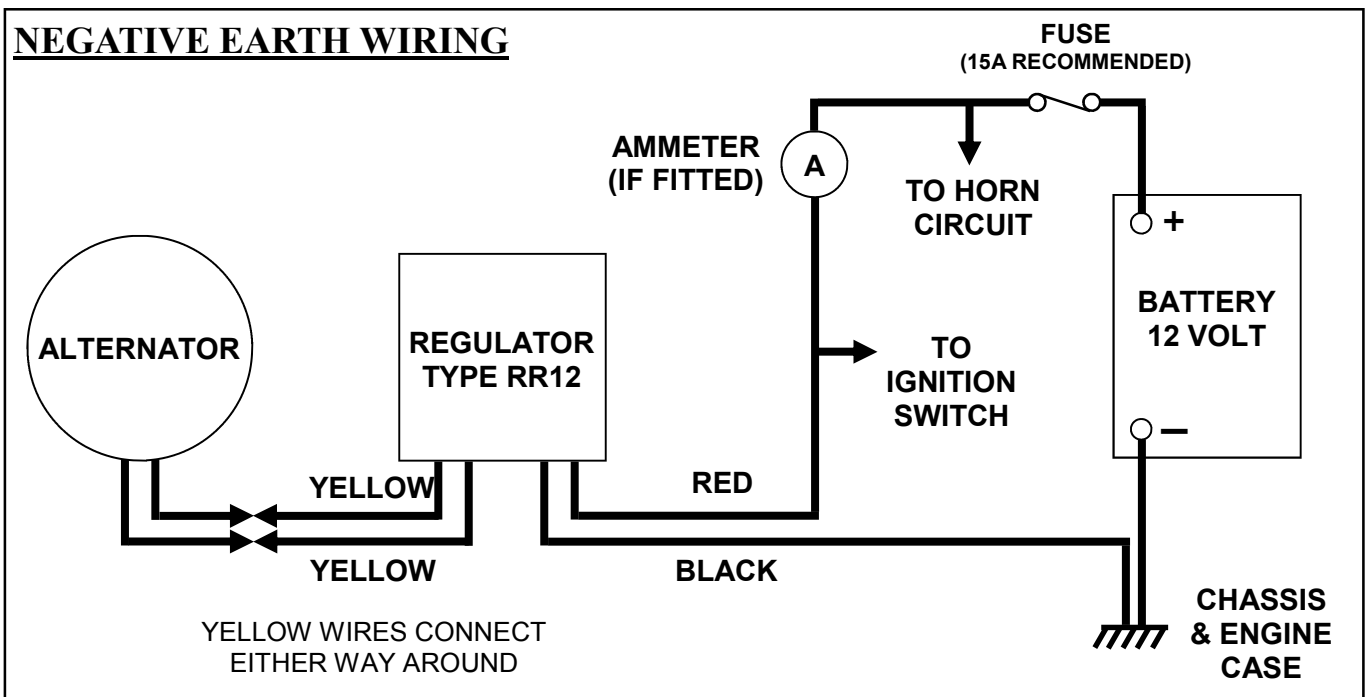

NOTES:

For 3 wire alternators, as fitted to early British bikes (usually with 6 volt electrics), join two of the wires together, as follows:

<u>GREEN/YELLOW</u>	JOINS TO	<u>GREEN/BLACK</u>	⇒	CONNECT TO ONE YELLOW WIRE
<u>GREEN/WHITE</u>			⇒	CONNECT TO OTHER YELLOW WIRE
<u>GREEN/YELLOW</u>	JOINS TO	<u>DARK GREEN</u>	⇒	CONNECT TO ONE YELLOW WIRE
<u>LIGHT GREEN</u>			⇒	CONNECT TO OTHER YELLOW WIRE
<u>MID GREEN</u>	JOINS TO	<u>DARK GREEN</u>	⇒	CONNECT TO ONE YELLOW WIRE
<u>LIGHT GREEN</u>			⇒	CONNECT TO OTHER YELLOW WIRE